

INSTALLATION & OPERATING INSTRUCTION MANUAL

To be provided to the owner/user.

TECHNICAL SUPPORT

(800) 652-0657

Monday - Friday

8 am - 5 pm PST

DIGNITY SERIES

Models

2653

3052

3053

3153

3153-D

BUILDER SERIES

Models

3260

3260-D

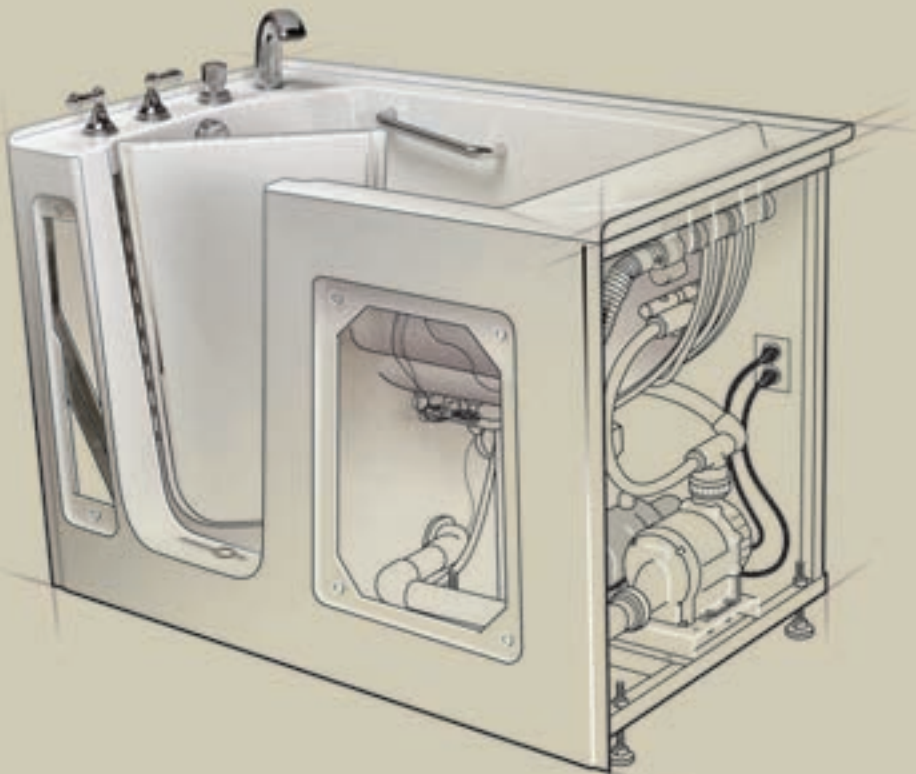

WALK IN BATHTUBS

TABLE OF CONTENTS

Important Safety Instructions.....	2
Warranty Confirmation & Product Registration.....	4
Installation Instructions	5
Pre-Installation Procedures.....	5
Installation Procedures	6
Electrical Instructions for Hydro Massage System.....	6
Electrical Instructions for Air Massage System	7
Electrical Instructions for Hydro & Air Massage System Wiring	7
Post Installation Testing and Cleaning.....	8
Cleaning	8
Installation Details (Dignity Series).....	9
Model Specifications (Dignity Series).....	10-11
Installation Details (Builder Series).....	12
Model Specifications (Builder Series)	13
Operating Instructions	
General	14
Hydro Massage.....	14
Air Massage	15
Hydro & Air Massage.....	15
Care and Maintenance.....	16
Troubleshooting Guide.....	17
Warranty.....	18
Notes.....	19-20

IMPORTANT SAFETY INSTRUCTIONS

INSTRUCTIONS PERTAINING TO RISK OF FIRE, ELECTRIC SHOCK, OR INJURY TO PERSONS.

WARNING: When using this unit, basic precautions should be followed, including the following:

READ AND FOLLOW ALL INSTRUCTIONS

DANGER! TO REDUCE THE RISK OF INJURY:

- A. Do not permit children to use this unit unless an adult closely supervises them at all times. Supervision is also required when an elderly or handicapped individual uses whirlpool bath.
- B. Use this unit only for its intended use as described in this manual. Do not use attachments not recommended by the manufacturer.
- C. Do not operate this unit without the guard over the suction fitting. The guard is a safety device that reduces the potential hazard of hair or body entrapment. **KEEP HAIR AND BODY AWAY FROM SUCTION GUARD WHEN PUMP IS RUNNING.**
- D. Never operate electrically connected devices in or near the bath. No electric appliances should be within 5 feet/1.5 meters of this bathtub (hair dryers, lamp, telephone, radio, television, etc).
- E. Never drop or insert any object in any opening within the whirlpool.
- F. Since excessive water temperatures have a high potential for causing fetal damage during the early months of pregnancy, pregnant or possibly pregnant women should limit whirlpool water temperatures to 38°C (100°F).
- G. The use of drugs or alcoholic beverages before or during whirlpool use may lead to unconsciousness with the possibility of drowning.
- H. Persons with a medical history of heart disease, low or high blood pressure, circulatory system problems or diabetes should consult a physician before using a whirlpool.
- I. Persons using medication should consult a physician before using a whirlpool since medication may induce drowsiness while other medication may affect heart rate, blood pressure and circulation.
- J. The water in a whirlpool should never exceed 40°C (104°F). Water temperatures between 38°C (100°F) and 40°C (104°F) are considered safe for a healthy adult. Use time should be limited to approximately 30 minutes, followed by a shower to cool down. Lower water temperatures are recommended for extended use (exceeding 10-15 minutes) and are definitely recommended for younger children. If you become nauseous, dizzy or develop a headache, get out at once and cool down. Get medical attention if symptoms persist. Check with a physician before using whirlpool again
- H. This unit must be connected to a circuit that is protected by a Ground Fault Circuit Interrupter (GFCI). the GFCI should be provided and installed by a licensed electrician and tested on a regular basis (at least monthly). To test the GFCI push the **TEST** button. The GFCI should interrupt the power. Push the **RESET** button and the power should be restored. If the GFCI fails to operate in this manner there is a possibility of a electric shock. **DO NOT OPERATE THIS UNIT.** Disconnect the unit and have the problem corrected by a licensed electrician before using.

CAUTION: DO NOT USE HARSH ABRASIVES OR SOLVENTS FOR CLEANING THIS UNIT.

SAVE THESE INSTRUCTIONS

IMPORTANT!

PLEASE CHECK ENTIRE UNIT FOR ANY DAMAGE.

IF IT APPEARS DAMAGED, CONTACT HOME LIVING SOLUTIONS IMMEDIATELY.

WARRANTY DOES NOT COVER DAMAGES THAT OCCUR IN TRANSIT.

HOME LIVING SOLUTIONS, LLC

Warranty Confirmation & Product Registration Information

IMPORTANT:

To ensure that your warranty is registered and confirmed with the manufacturer, please take a few moments to complete, sign and return The product Registration Card (below) within 30 days of date of purchase.

WARRANTY CONFIRMATION:

By returning this Product Registration Card we Confirm the date of purchase for your new product. This confirmation will allow Home Living Solutions, LLC to process any warranty claims.

PURCHASE REGISTRATION:

The information provided on Product Registration Card will be kept on file with Home Living Solutions LLC as official Purchase Registration.

While completing the card, please take time to also fill the owner information to the right, as this will help expedite any warranty claim, should the need arise.

OWNER INFORMATION:

Model Name/Number

Serial Number

Purchase Date

Dealer



Home Living Solutions, LLC

Product Registration Card

To ensure that your warranty is registered with Home Living Solutions, LLC complete, sign and return This registration card within 30 days of the purchase or installation. NOTE: Your warranty will not be Recognized by Home Living Solutions, LLC Unless this card is fully completed and returned to Home Living Solutions, LLC Home Living Solution LLC, 42261 Zevo Dr, Temecula, CA 92590

Name _____ Dealer Name _____

Address _____ City _____

City _____ Tub Model _____

Phone _____ Color _____

Date Purchased _____ Serial No. _____

I have read the Home Living Solutions, LLC Owners Manual carefully and understand and agree that any Installation, Operation or Maintenance of Walk-in Bathtub must be done strictly in accordance with instructions and guidelines contained in the Home Living Solutions, LLC. Owner's Manual and installation guide.

SIGNATURE _____ DATE _____

INSTALLATION INSTRUCTIONS

READ ALL INSTRUCTIONS CAREFULLY BEFORE INSTALLATION

WARNING: WHEN USING ELECTRICAL PRODUCTS, BASIC PRECAUTIONS SHOULD ALWAYS BE FOLLOWED, INCLUDING THE FOLLOWING:

DANGER: RISK OF ELECTRICAL SHOCK. Connect only to a circuit protected by a ground-fault circuit-interrupter (GFCI). Grounding is required; all electrical connections should be made by a licensed electrician, in accordance with the requirements of national electrical codes and procedures.

INSTALLER / OWNER BEARS ALL RESPONSIBILITY TO COMPLY WITH ALL STATE AND LOCAL BUILDING CODES WHEN INSTALLING THIS UNIT

PRE-INSTALLATION PROCEDURES:

1. **Immediately** unpack and inspect the unit thoroughly for freight damage, even if there is no visible damage to the carton. If necessary, contact your dealer/distributor immediately to file a freight claim.
2. All walk-in baths are water tested and operated in our factory prior to shipment. However rough handling may cause leaks which may be detected (if water tested) prior to installation.
3. Place the tub on a flat surface in an area where it may be drained after testing.
4. Never lift the tub by any portion of the hydro massage system.
5. Place a plug or tape over the drain, fill the tub with water to the overflow and allow standing for a few minutes.
6. Using an extension cord Plug in pump cord and run the system for 10 minutes. Inspect the tub for leaks. Turn system off then let stand for 10 minutes. Inspect tub completely (around pump, all plumbing fittings and door for leaks) any defect must be reported to your dealer/distributor prior to installation in order to have it covered under warranty.
7. Check to ensure that your installation will conform to all applicable codes and secure necessary permits. All electrical and plumbing connections should be made by a qualified electricians and plumbers.

IMPORTANT: FAILURE TO FOLLOW THE PRE-INSTALLATION PROCEDURES, MANUFACTURER WILL NOT BE LIABLE FOR THE REMOVAL OR INSTALLATION OF THE BATHTUB, AND COULD RESULT IN TERMINATION OF THE WARRANTY.

INSTALLATION PROCEDURES:

1. For framing rough-in dimensions, see Installation Diagrams on page 9.
2. The bathtub must be set on a solid flat surface capable of supporting the tub with the use of the six (6) adjustable feet and it is required that all the feet come in contact with the floor.
3. The plumbing connections (faucet, hoses, and waste/overflow) should be made prior to setting tub in-place.
4. The filler panel is used only for 60" installations.
5. The door drain assembly is attached at one end at the factory. The drain body is to be installed between the drain shoe and the drain tee.

NOTE: The drain body and hose must be installed horizontal. See door drain illustration below.

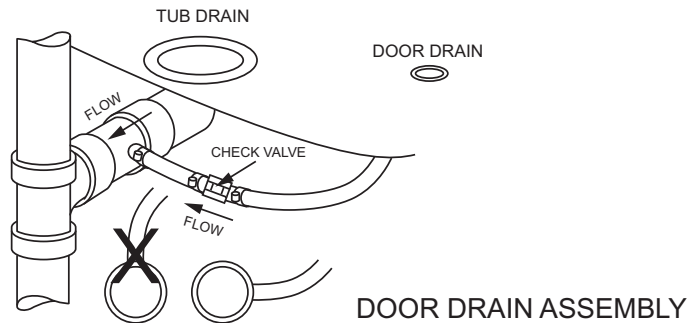

ELECTRICAL INSTRUCTIONS: HYDRO MASSAGE SYSTEM

1. Hydro massage system requires one (1) dedicated 15-amp, 120 volt service.
2. A receptacle with a 15-amp configuration must be provided by the electrician.

NOTE: Provide a power supply outlet (receptacle) appropriately rated for each load. For voltage and current requirements refer to the label on each load.

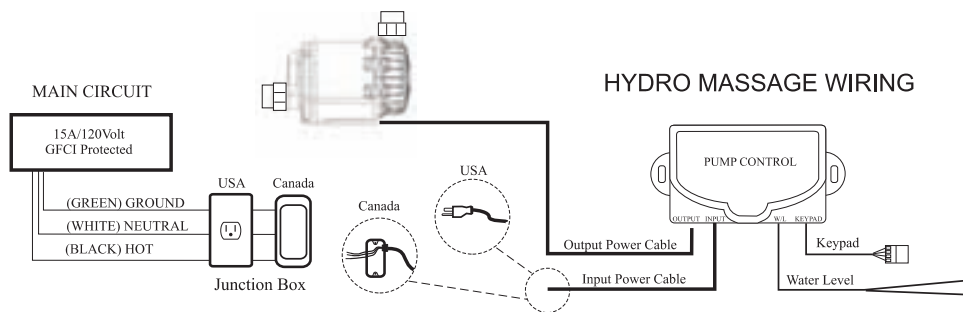

ELECTRICAL INSTRUCTIONS: AIR MESSAGE SYSTEM

1. Air massage system requires one (1) dedicated 15-amp, 120-volt service.
2. A receptacle with a 15-amp configuration must be provided by the electrician.
3. Connect a # 8 bare copper bonding wire from the blower control box to the cold water plumbing or other suitable ground. Grounding is required.

NOTE: Provide a power supply outlet (receptacle) appropriately rated for each load. For voltage and current requirements refer to the label on each load.

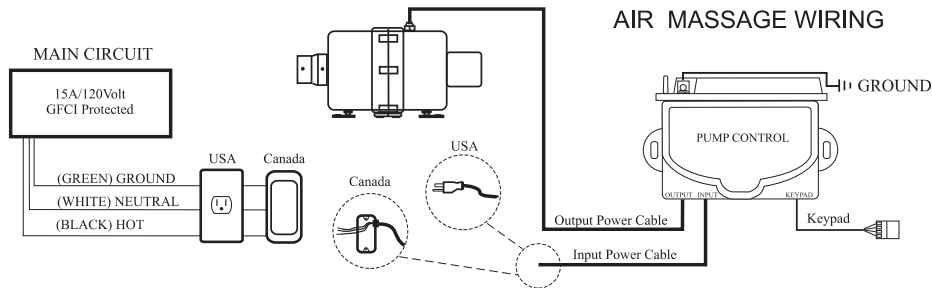

ELECTRICAL INSTRUCTIONS: HYDRO & AIR MESSAGE WIRING

1. Hydro massage system with air massage system requires two dedicated 15-amp 120-volt services one (1) for hydro massage pump and one (1) for the air massage blower.
2. Two dedicated 15-amp configuration must be provided by the electrician.
3. Connect a # 8 bare copper bonding wire from the blower control box to the cold water plumbing or other suitable ground. Grounding is required.

NOTE: Provide a power supply outlet (receptacle) appropriately rated for each load. For voltage and current requirements refer to the label on each load.

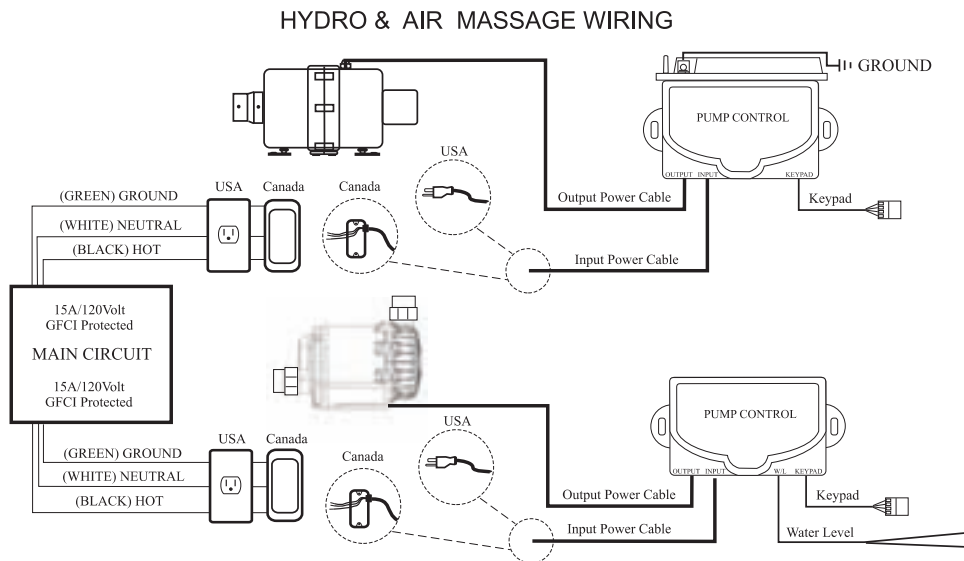

POST - INSTALLATION TESTING AND CLEANING:

SYSTEM TEST: After installation make sure all plumbing connections and hydro massage and air massage system connections are correctly installed, run the following tests.

1. Before filling the tub with water, be sure to remove all loose debris from tub. Wipe down the door seal using a damp cloth, as well as the surface in the door jamb that will come in contact with the door seal.
2. Fill the tub to the overflow and check for leaks. Check by hand where visual verification is not possible.
3. Turn the pump and or blower on and let it run for at least 15 minutes. Check for leaks while the pump or pumps are running and again after the pump or pumps are turned off. Check by hand where visual verification is not possible.

Refer all service issues to your dealer/distributor.

CLEANING:

WARNING: Under no circumstances use wire brushes, metal sponges, knives, steel wool or scouring pads on any part of the tub, or solvents that contain petroleum distillates such as acetone, lacquer, paint thinner, benzene or abrasive cleanser on any part of the tub. **DO NOT USE ammonia or chlorine-based agents on any plated surface.** These products will remove the plating, thereby voiding the warranty on the plated finish.

1. Remove any blobs of plaster and/or dabs of paint that have adhered to the surface by gently scraping them off with the sharpened edge of a makeshift spatula fashioned out of wood.
2. Oil or grease spots can be lifted with denatured alcohol.
3. Use liquid, non-bleach and automatic dishwashing detergent to remove any construction residue.
4. For tough stains and surface scratches lightly rubbing with a liquid cleaning compound (such as polishing compound used for cars), followed by a light application of liquid or paste wax, will restore luster to any dulled surface.
5. Clean plated surfaces with warm water only.

SAVE THESE INSTRUCTIONS

INSTALLATION DETAILS

DIGNITY SERIES

MODEL	OPERATING CAPACITY
2653	42 gallons
3052	75 gallons
3053	48 gallons
3153	54 gallons
3153-D	85 gallons

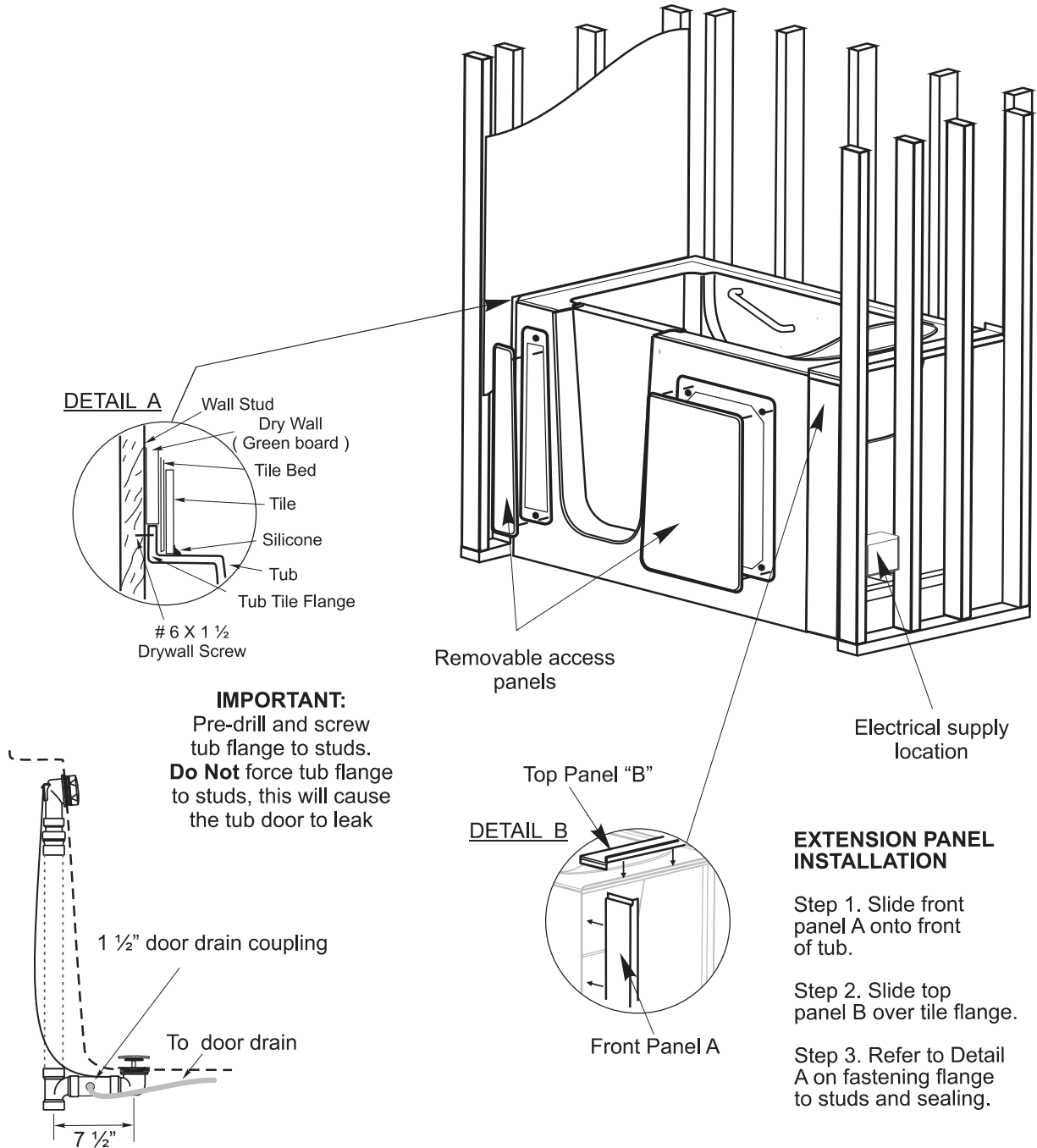

MODEL SPECIFICATIONS

Dignity Series

3153

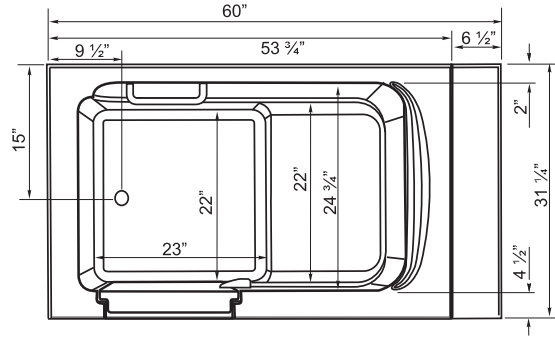
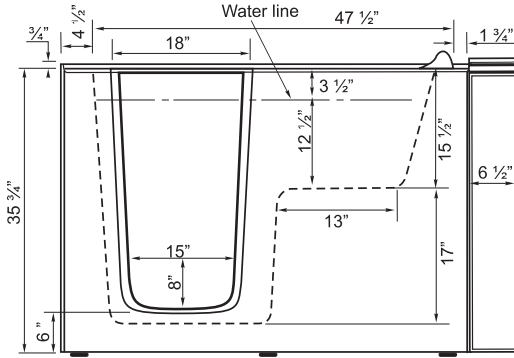

3153-D

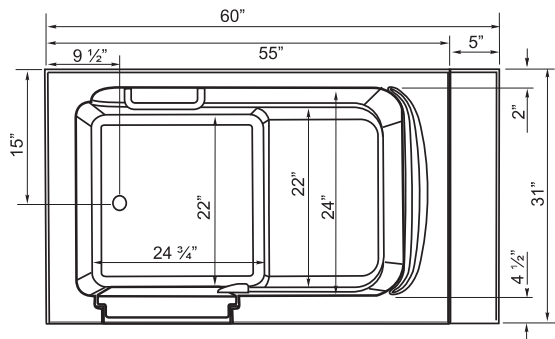
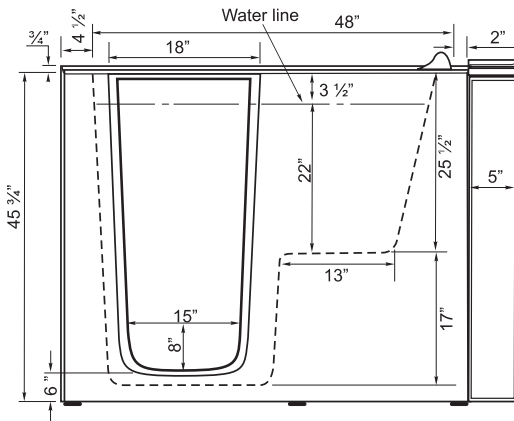

INSTALLATION DETAILS

BUILDER SERIES

MODEL	OPERATING CAPACITY	ACCESS PANELS
3260	70 gallons	optional
3260-D	83 gallons	standard

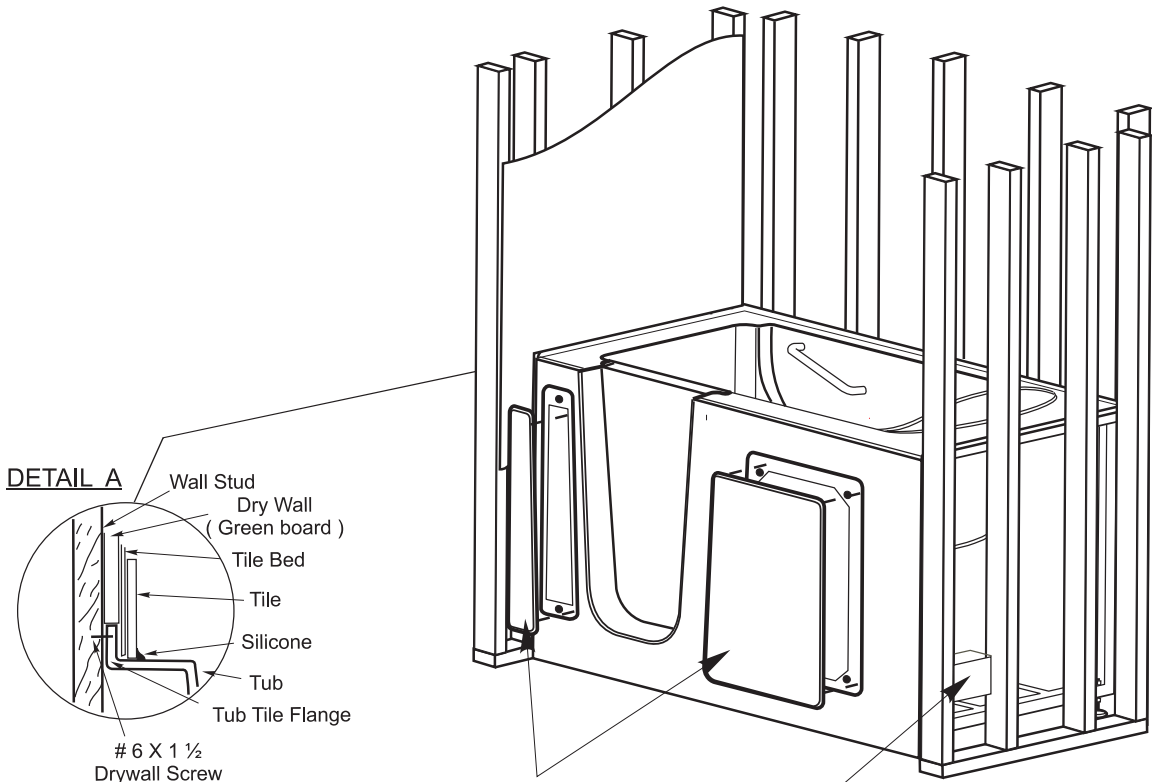

IMPORTANT:
Pre-drill and screw tub flange to studs.
Do Not force tub flange to studs, this will cause the tub door to leak

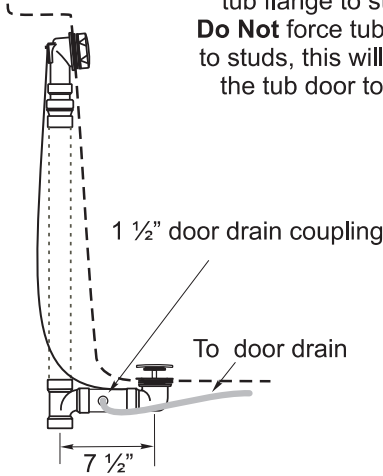

MODEL SPECIFICATIONS

Builder Series

3260

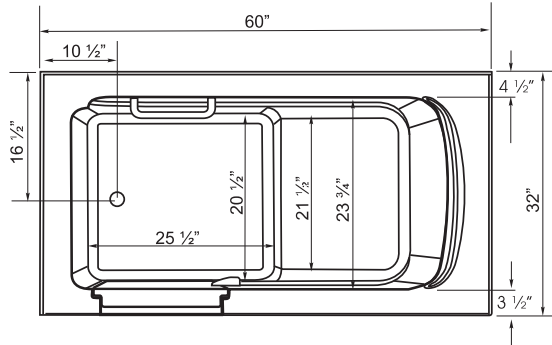
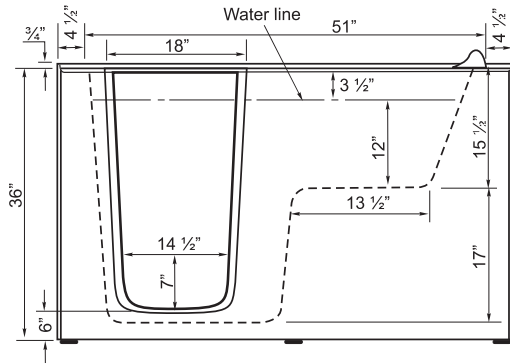

3260-D

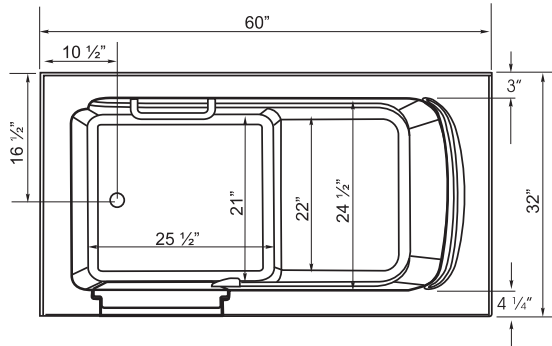
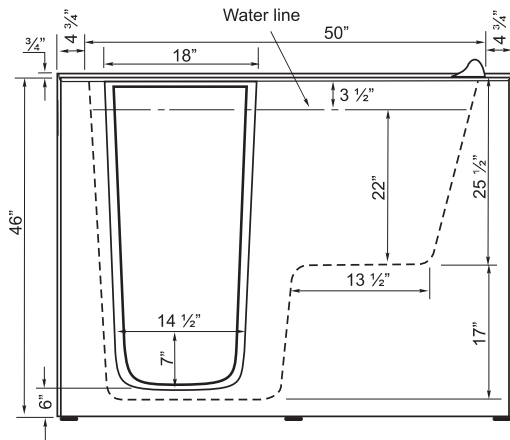

CONGRATULATIONS!

You made an excellent decision. You now own the best!

Your walk-in tub is going to be a source of enjoyment and relaxation for a long time to come. Not only will your walk-in tub provide you with the optimum in bathing pleasure, but it can also be of considerable therapeutic value.

Your walk-in tub was specifically designed to deliver continuous dependable operation. All hydro massage system fittings and air massage fittings are manufactured of strong, highly inert ABS and PVC materials to prevent water discoloration and ensure long life. The electrical components also conform to and exceed all of the applicable safety standards. Every walk-in bath is thoroughly tested and inspected before leaving the factory to ensure your continued enjoyment and peace of mind of ownership.

IMPORTANT OPERATING INSTRUCTIONS

CAUTION: DO NOT OPERATE THE HYDRO MASSAGE SYSTEM WITH ANY PARTS OR FITTINGS REMOVED.

1. Use this unit only for its intended use as described in the manual.
2. To avoid injury, exercise care when entering or exiting the hydro massage bathtub, the floor may be slippery.
3. Do not use door as support while entering or exiting the hydro massage bathtub, as door may swing with applied weight.
4. Do not add any liquids or powders to the water, especially foamy, bubbly or oily types, other than the automatic dish detergent used for cleaning the hydro massage system
5. Risk of hypothermia and drowning, (refer to IMPORTANT SAFETY INSTRUCTIONS) **Do not** use hydro massage bathtub after strenuous exercise. However under no circumstances use a bathtub with water above 104°F (40°C).
6. Do not open door until all water has been drained from bathtub.
7. Be careful while exiting tub, water on the floor or in tub may cause slippery conditions.
8. Enter your bathtub and latch the door securely. The downward motion of the door level locks and seals the door.
9. Be certain tub drain is open as first water coming from tub spout may be too cold or too hot. Carefully test water temperature by slowly moving hand into water stream.
10. After adjusting water temperature, move the drain valve handle all the way to the left to close the tub drain.

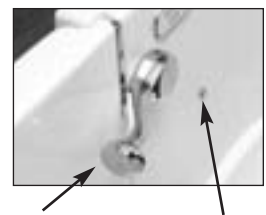

DOOR LOCKED WATER SENSOR

HYDRO MASSAGE OPERATION:

1. For the hydro massage system to operate, you must have the water level above the small round chrome water level sensor in order for the jets to work.
2. To operate the hydro massage system; locate the touch pad on the side of the tub. Press the touch pad and the jets will come on, by pressing it again the jets will turn off.
3. Time and duration is simply determined by the auto-shut off timer that will operate for approximately 15–20 minutes or this can be done manually by using the touch pad.
4. Direction of the jets can be controlled by adjusting the eyeballs of the jets to the desired direction. Back jets can be individually adjusted from off to full by rotating the chrome ring. The 180° rotation of this ring provides a wide range of comfort settings.
5. If you drain the tub, or the water level falls below the small round chrome water level sensor, the hydro massage pump will automatically shut down. Just add water until the sensor is covered and use the touch pad to restart the system.

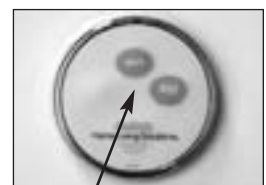

ON/OFF BUTTONS

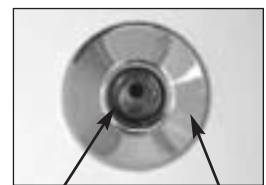

JET EYEBALL CHROME RING

AIR MASSAGE OPERATION:

1. To operate the air massage system, locate the touch pad on the side wall of the tub. Pressing the on off button will start and stop the blower. The blower always starts at maximum speed
2. Pressing and holding this key will increase or decrease the Blower speed until desired level is reached.
3. Pressing this button once, the blower speed will vary gradually From maximum to minimum and back to maximum. 2nd press, system turns off and on, alternately. 3rd press, returns to maximum speed.
4. The air massage system will stop automatically after 20 minutes.
5. **Advanced function:** An automatic drying cycle will start 20 minutes after the blower is turned off.

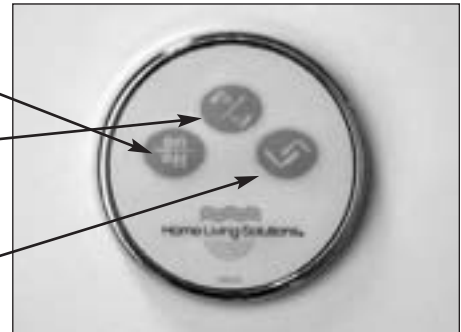

HYDRO AND AIR MASSAGE OPERATION:

1. To operate the air massage system, locate the touch pad on the side wall of the tub. Pressing the on off button will start and stop the blower. The blower always starts at maximum speed
2. Pressing and holding this key will increase or decrease the Blower speed until desired level is reached.
3. Pressing this button once, the blower speed will vary gradually from maximum to minimum and back to maximum. 2nd press, system turns off and on, alternately. 3rd press, returns to maximum speed.
4. The air massage system will stop automatically after 20 minutes.
5. **Advanced function:** An automatic drying cycle will start 20 minutes after the blower is turned off

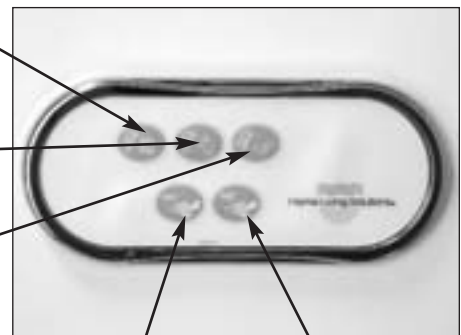

HYDRO PUMP ON HYDRO PUMP OFF

6. For the hydro massage system to operate, you must have the water level above the small round chrome water level sensor in order for the jets to work.
7. To operate the hydro massage system; locate the touch pad on the side of the tub. Pressing “on” will turn the jets on, pressing “off” will turn the jets off.
8. Time and duration is simply determined by the auto-shut off timer that will operate for approximately 15–20 minutes or this can be done manually by using the touch pad
9. Direction of the jets can be controlled by adjusting the eyeballs of the jets to the desired direction. Back jets can be individually adjusted from off to full by rotating the chrome ring. The 180° rotation of this ring provides a wide range of comfort settings.
10. If you drain the tub, or the water level falls below the small round chrome water level sensor, the hydro massage pump will automatically shut down. Just add water until the sensor is covered and use the touch pad to restart the system.



DOOR LOCKED WATER SENSOR

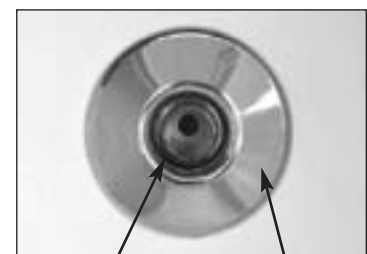

JET EYEBALL CHROME RING

CARE AND MAINTENANCE

Regular care of your walk-in tub with the hydro massage system will keep it clean and working at its best. This care should include the tub, the trim and fittings and internal water-carrying part of the pipe system.

No maintenance is required for the pump or the motor powering it. The motor is lubricated for life. The shaft and seals in the pump are water lubricated and self-adjusting.

Because of the detrimental effects that mineral deposits, soap scum and bacteria have on finished surfaces, it is important to keep your bathtub and the fixtures (fittings) of your walk-in hydro massage system clean on a regular basis. The best way to counteract the soiling and often time corrosive action of these residues is to prevent water from remaining on any finished surface.

NOTE: DO NOT USE OIL OR OIL BASED BATH ADDITIVES.

If you won't to use any kind of bath additives, use only a small amount of low-foaming powder or crystal substance. The hydro massage action intensifies the foaming properties of soap.

REGULAR CLEANING:

1. After each use, rinse all exposed surfaces of the walk-in tub with clear warm water, then wipe off all standing water until completely dry.
2. Once a week, wash all exposed surfaces of the bathtub with mild solution. Check for stubborn spots. Oily or greasy spots can be lifted with denatured alcohol.
3. To preserve the tub finish, waxing is recommended. Regular use of a quality marine wax will maintain the finish of your walk-in tub.
4. It is especially **IMPORTANT** to wipe down the door seal and door jamb after each use in order to maintain the integrity of the water seal. In order to keep the door seal and door jamb clean and not accumulate dirt or debris of any kind, clean seal and jamb with a mild detergent and warm water using a soft cloth.
5. **Once a month, purge and clean the entire system using liquid automatic dish detergent**, which will remove body and bath oils, soap residue and other sources that can contribute to bacterial growth in the hydro massage system. Fill the tub with warm water to the low water sensor. Using a spoonful of dishwasher detergent, (**not hand soap**) turn on the hydro massage system for 15 minutes, then drain tub. Now refill the tub with warm water and run system for another 15 minutes to rinse out the plumbing. Using your hand held shower rinse out tub then dry with a soft cloth.

WARNING: Under no circumstances use wire brushes, metal sponges, knives, steel wool or scouring pads on any part of the tub, or solvents that contain petroleum distillates such as acetone, lacquer, paint thinner, benzene or abrasive cleanser on any part of the tub. DO NOT USE ammonia or chlorine-based agents on any plated surface. These products will remove the plating, thereby voiding the warranty on the plated finish.

USER SERVICE INSTRUCTIONS:

1. There are no user serviceable parts. All service, repairs must be performed by a qualified service technician in accordance with all applicable local and national codes.
2. For replacement parts contact your dealer/distributor.

TROUBLESHOOTING GUIDE

WARNING: Always turn off power at main electrical service panel when servicing your walk in bathtub.

SYMPTOMS	PROBLEMS	SOLUTIONS
Motor will not start.	GFCI or breaker in off position. Not enough water in tub. Disconnected or defective wiring	Reset GFCI or breaker. Add water to cover low water sensor. Check and reconnect if needed.
Breaker trips repeatedly.	Short between bath and breaker. GFCI or breaker defective.	Check for short in wiring. Replace GFCI or breaker.
Motor does not reach full Speed.	Low voltage. Wiring too small.	Contact your electrician. Contact your electrician.
Motor overheats.	Low voltage. Wiring too small. Inadequate ventilation.	Contact your electrician. Contact your electrician. Gain ventilation to motor.
Leaking around pump.	Loose unions. O-ring missing.	Hand tighten unions. Replace O-ring.
No pressure out of back jets	Jet in closed position.	Turn jet face ½ turn counter clockwise.
No air out of lower air jets in low speed.	Speed of blower set to low.	Increase blower speed until all jets are working.

DOOR SEAL LEAKING:

If a small leak has been detected around the door, check closely for any accumulation of dirt or debris. Any small collection of either on the door seal or where the seal comes in contact with the door jamb could result in a minor leak through the door seal.

1. Before filling tub with water, be sure to wipe down the door seal using a damp soft cloth, as well as the surface on the door jamb that will come in contact with the seal.
2. Once the above surfaces have been wiped clean, be sure that when closing the door, the latch is completely locked forward

NOTE: When draining the water from the tub, be sure that the door latch is in the locked position (forward). If the latch is not secure when draining the tub, as the water level lowers, the pressure on the door will be reduced, thus increasing the possibility of a leak around the door.



LIMITED PRODUCT WARRANTY

THIS LIMITED PRODUCT WARRANTY ("WARRANTY") IS PROVIDED BY HOME LIVING SOLUTIONS LLC ("HLS") TO YOU, THE ORIGINAL PURCHASER ("PURCHASER"). THIS WARRANTY IS NON-TRANSFERABLE AND APPLIES ONLY TO THE PURCHASER. DIFFERENT WARRANTY PERIODS APPLY. WARRANTIES ARE AVAILABLE FOR INSPECTION PRIOR TO SIGNING OF THE SALES AGREEMENT OR PURCHASE ORDER. THE PRODUCT REGISTRATION CARD MUST BE MAILED TO HOME LIVING SOLUTIONS LLC, 42261 ZEVO DRIVE, TEMECULA, CALIFORNIA 92590 TO ACTIVATE THIS WARRANTY.

Bathtub Shell, Frame, Finish – Limited Lifetime Warranty: Subject to the terms and conditions herein, HLS hereby warrants to the Purchaser that the bathtub shell, frame, and finish will not fade, crack, delaminate, or blister for the life of the product.

Door Seal - Limited Lifetime Warranty: Subject to the terms and conditions herein, HLS warrants that the door seal will not fail or become inoperable for the life of the product.

Fitting and Component Parts – Limited 10-Year Warranty: Subject to the terms and conditions herein, HLS hereby warrants to the Purchaser that the product's fittings and component parts, including motors, electronic controls, faucet, waste and overflow, and all plated finishes, will not fail or become inoperable for a period of 10 years from the date of installation.

How to Obtain Warranty Service: Questions or concerns regarding this Warranty should be directed to Customer Service at (877) 711-TUBS (8227) Monday – Friday 8:00 a.m. – 5:00 p.m. PST. To submit a claim, a copy of this Warranty and a copy of the Purchaser's sales agreement or purchase order must be submitted in writing by registered mail to Home Living Solutions LLC, 42261 Zevo Drive, Temecula, California 92590. Please include the reason for the claim. Claims must be submitted to HLS promptly after discovery of the claimed defect and within the applicable warranty period. HLS will then schedule an appointment to inspect the premises and the warranty claim within a reasonable period of time after having received the claim. If after inspection, HLS determines that a valid claim exists under one or more of the warranties, HLS will repair, re-install, replace, or refund the purchase price of the failing product, at HLS' option. If HLS determines that the defective product or component cannot be repaired, HLS shall provide the Purchaser with a new product or component thereof and it shall be the responsibility of the Purchaser to arrange for and pay for installation. If HLS determines to replace any or all product(s), and if such product(s) as originally installed is/are no longer available, HLS shall have the right to substitute product(s) designated by HLS to be of equal quality. Replacement of a product or component thereof does not renew the warranty period. If, at HLS' option, a purchase price refund is conveyed to the Purchaser, then all warranties are terminated, and the repair, replacement, or removal of HLS products shall become the sole responsibility of the Purchaser. No warranties are valid unless and until the Purchaser has made full payment under the original sales agreement/purchase order and all addenda thereto.

What Is Not Covered: These warranties are granted by HLS to the Purchaser only and only materials purchased from HLS and installed by HLS-approved installers are covered by these warranties. HLS does not warrant the installation of any product or component thereof. The Purchaser shall be liable for all shipping and handling charges under this Warranty. Should service be required under any express warranty described herein (as solely determined by HLS) for a period of 1 year from the date of installation, HLS will arrange for the repair or replacement of the defective product or component thereof at no charge to the Purchaser. HLS shall not be responsible for any water damage to structures or property for any reason including but not limited to manufacturer defects or improper installation. All warranties assume normal and reasonable use of products or components. Minor color or textural variations from lot-to-lot of product are not product or installation defects. These warranties do not cover any other damage, workmanship, or material failure including, but not limited to, damage caused by occurrences beyond the control of HLS, such as settlement of the building, failure of the structure (including foundations and walls), use of incompatible accessories, removal, repair, or re-installation of any HLS products or components by other than HLS-approved installers, normal weathering, corrosive effects of salt air and chemical pollutants, excessive wear, scouring due to cleaning, normal fading, deterioration of caulking compounds, fire, flood, lightning, high winds (in excess of warranted speed herein), windblown objects, earthquakes, hurricanes, ice dams, icicles and/or ice storms, atmospheric conditions or weather of catastrophic nature as defined by the U.S. National Weather Service, other acts of God, intentional acts, unreasonable use, vandalism, or pollution. These warranties also will not apply to damages resulting from the failure to provide reasonable maintenance. If replacement of the product or components thereof is required as a result of actions set forth in this paragraph, Purchaser shall be charged the full cost of the replacement product. These warranties do not apply to damages due to or arising from the identification, detection, abatement, encapsulation, or removal of mold, asbestos, lead-based products, or other hazardous substances inside or outside of the structure being improved.

What Voids These Warranties: Installation, removal, painting, repair, adjustment, tampering, or re-installation of any HLS products or components by other than an HLS-approved installers voids any and all warranties within this Warranty, and HLS expressly disclaims any liability for any costs, defects, or damages with respect to such actions.

Remedies and Rights: These warranties of HLS products are the only express warranties provided by HLS. No employee, representative, agent, nor any other person (including dealers, retailers, distributors or contractors) has authority to assume or incur on behalf of HLS any obligation, liability, or responsibility in place of or in addition to these warranties. IN NO EVENT SHALL THE DURATION OF ANY IMPLIED WARRANTY OF MERCHANTABILITY OR FITNESS FOR A PARTICULAR PURPOSE BE LONGER THAN THE DURATION OF OWNERSHIP AND OCCUPATION BY THE PURCHASER OF THE HOME ON WHICH THE HLS PRODUCT IS INSTALLED. EXCEPT FOR THE WARRANTY PROVIDED HEREIN, HLS MAKES NO WARRANTY OF ANY KIND, EXPRESS, IMPLIED, OR STATUTORY, INCLUDING, WITHOUT LIMITATION, ANY WARRANTY OF NONINFRINGEMENT, MERCHANTABILITY, OR FITNESS FOR A PARTICULAR PURPOSE. HLS' LIABILITY TO THE PURCHASER UNDER THIS WARRANTY IS LIMITED TO THE AMOUNTS RECEIVED BY HLS FOR SERVICES RENDERED UNDER THE SALES AGREEMENT OR PURCHASE ORDER WITH THE PURCHASER. SOME STATES DO NOT PERMIT ANY LIMITATION ON THE LENGTH OF AN IMPLIED WARRANTY, AND THEREFORE THE IMMEDIATELY PRECEDING SENTENCE MAY NOT APPLY. IN NO EVENT SHALL HLS BE OBLIGATED OR LIABLE FOR INCIDENTAL, SPECIAL, INDIRECT, OR CONSEQUENTIAL DAMAGES OF ANY KIND FOR THE BREACH OF ANY EXPRESS OR IMPLIED WARRANTY OF HLS' PRODUCT. SOME STATES DO NOT ALLOW EXCLUSION OR LIMITATION OF INCIDENTAL OR CONSEQUENTIAL DAMAGES, AND THEREFORE SOME OR ALL OF THE IMMEDIATELY PRECEDING SENTENCE MAY NOT APPLY. THESE WARRANTIES PROVIDE SPECIFIC LEGAL RIGHTS, AND YOU MAY HAVE OTHER RIGHTS, WHICH VARY FROM STATE TO STATE.

CUSTOMER SERVICE

Contact Customer Service at (877) 711-TUBS (8227)
Monday – Friday 8:00 – 5:00 PST

TECHNICAL SUPPORT

(800) 652-0657

Monday - Friday

8 am - 5 pm PST

CUSTOMER SERVICE

(877) 711-TUBS (8827)

Monday - Friday

8 am - 5 pm PST

42261 Zevo Drive

Temecula, CA 92590

www.homelivingsolutions.com



WALK IN BATHTUBS